

template block frame

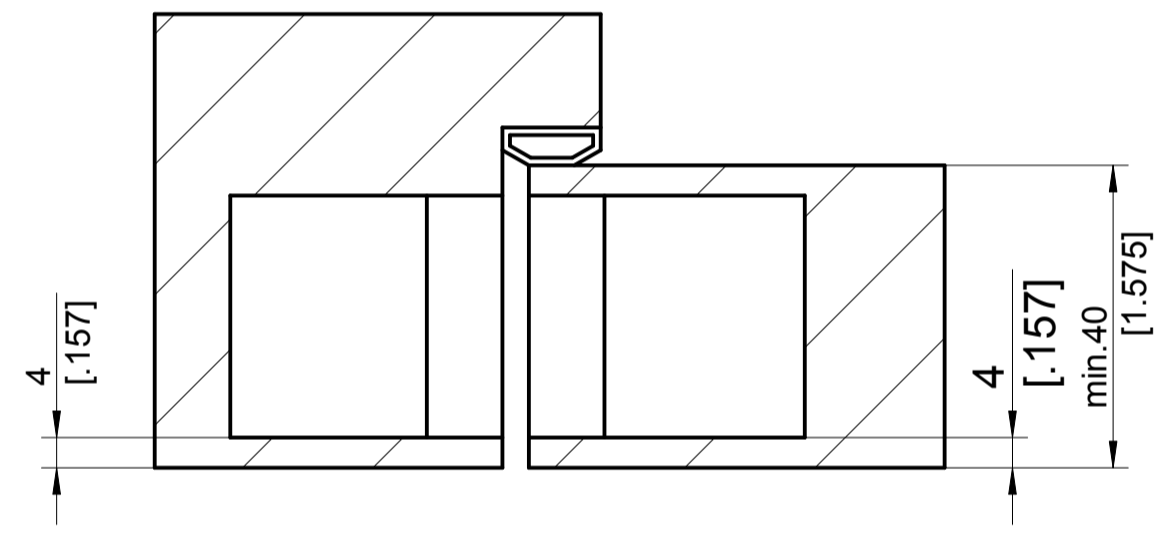

template door panel

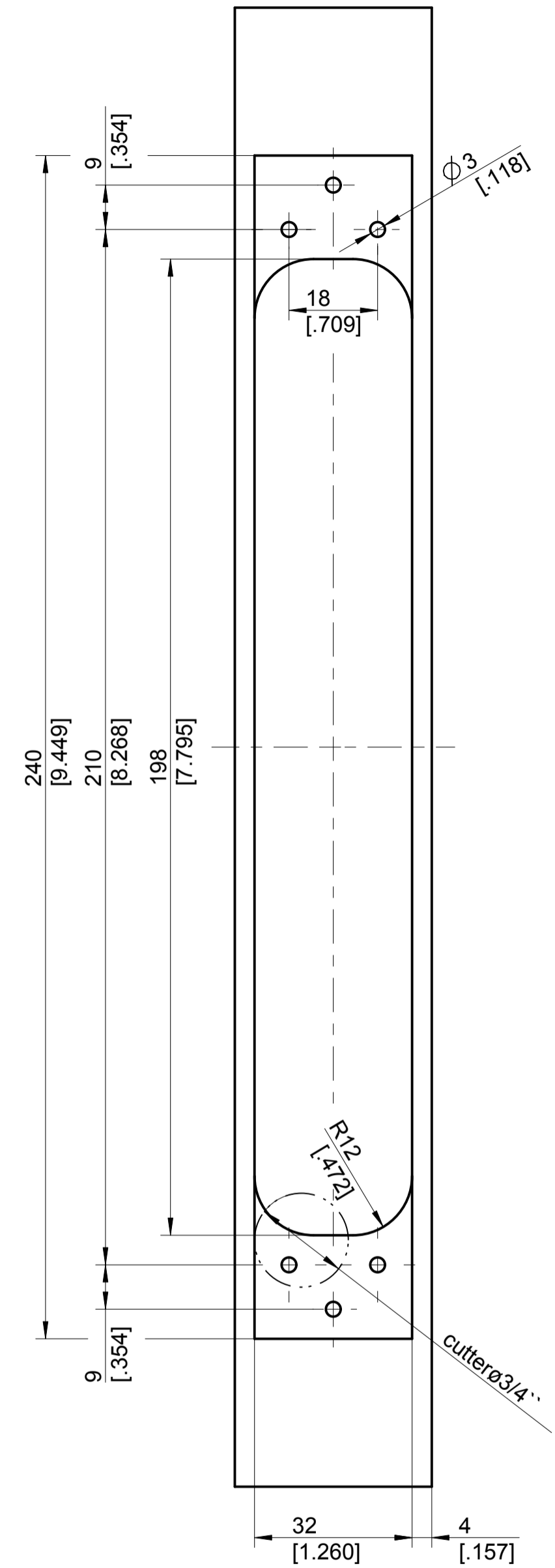
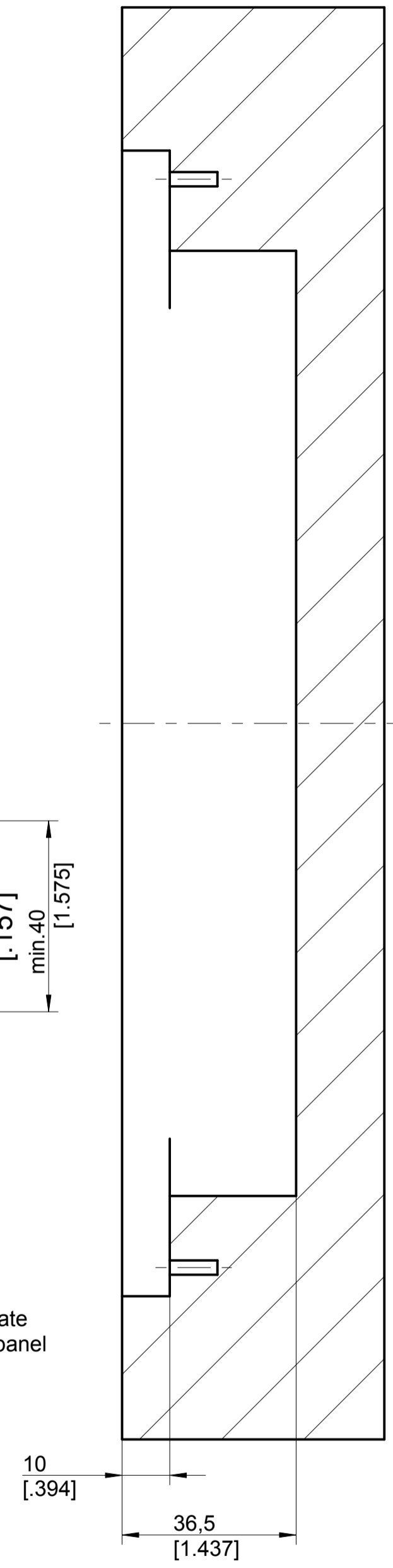

Kunde:USA			Zul. Abweichung nach DIN:	Werkstoff:	Maßstab:
- x -	-	-	-	-	1:1
- x -	-	-	-	-	-
- x -	-	-	Gew.	Benennung, Type:	
- x -	-	-	Datum	Name	Fräsbild Blockzarge
- x -	-	-	Gez. 02.08.18	Kirsch.	
- x -	-	-	Gepr. 16.08.18	Sabr.	TECTUS TE640-3D K US
- x -	-	-	Lebenszyklusphase:		
- x -	-	-	Serie		
- x -	-	-	Ersatz für/durch:		
- x -	-	-	Verkaufs.-Nr.:		
x			Proj. M.		
x			Format: A2		
x			Blatt:		
Zust.	Änderung	Datum	Name	Zeichnungs.-Nr.: 5 400696 0 00000	